

The Heck Reaction and Cinnamic Acid Synthesis by Heterogeneous Catalysis

PALLADIUM ON CARBON CATALYST GIVES IMPROVED PRODUCTION

By Valerie M. Wall, Amihai Eisenstadt, David J. Ager and Scott A. Laneman

NSC Technologies, Mount Prospect, Illinois, U.S.A.

The Heck reaction for the construction of carbon-carbon bonds, using palladium catalysts, is one of the most valuable strategies in organic chemistry and appears frequently in the literature, usually as homogeneous catalysis. In this review the progress made to date with this reaction is examined, together with the most discussed aspects of the Heck reaction, including a description of its mechanism and the conditions required for success. Some limitations to the homogeneous reaction are mentioned with reasons for proceeding with heterogeneous catalysts, in particular with palladium/carbon. Examples of various heterogeneous Heck reactions are presented and work that we are undertaking to develop methods for the production of cinnamic acids, useful as substrates for the synthesis of "unnatural" amino acids, is discussed. Finally, we present some results from our work using palladium/carbon catalysts for heterogeneous Heck reactions.

The Heck reaction is considered to be one of the more useful strategies in organic synthesis for the construction of carbon-carbon bonds. First discovered by Heck in 1968 (1), the reaction involves the palladium-catalysed coupling of aryl or alkenyl halides with alkenes, see Scheme I. It has since been expanded to include organometallic reagents (such as Grignard, organolithium and organoselenium reagents), aryl triflates, aryl diazonium salts, and boronic acids and esters as substrates.

The reaction has been comprehensively reviewed (2-7); indeed, a literature search for the "Heck Reaction" showed 11 "hits" for the initial period to 1980, 69 for 1981-1990, 279 for 1990-1995, and from 1995 to May 1999 this figure has increased to 419 (8).

The mechanism of the Heck reaction has been the subject of intense study and the one that is generally accepted is depicted in Scheme II (3, 5-7). The catalytic cycle can be considered in four stages:

- oxidative addition,
- co-ordination/insertion,
- β -hydride elimination/dissociation, and
- regeneration of the Pd(0) species to complete the catalytic cycle.

Traditionally, the Heck coupling reaction has been catalysed by PdL₄, PdCl₂L₂ or Pd(OAc)₂ with two equivalents of added ligand (L). Ligands employed in the Heck reaction include 1,10-phenanthroline derivatives (9, 10) and carbenes (11, 12), but mono- and bidentate phosphines, such as PPh₃ or P(*o*-tolyl)₃, are more

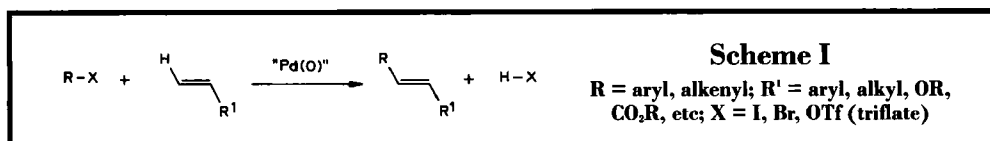

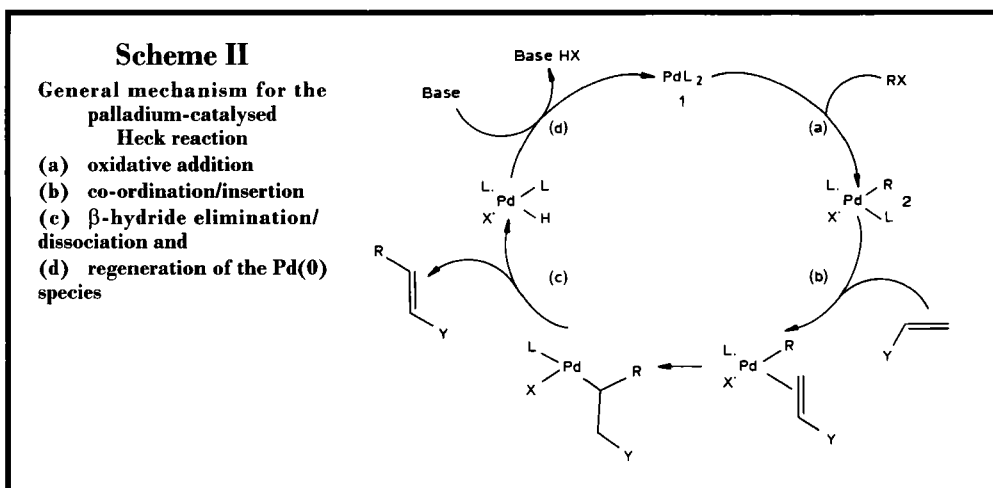

typical (4). The combined electronic and steric properties of the ligand affect both the stability of the intermediates as well as the activity and selectivities of the palladium catalyst. For the homogeneous reaction, the presence of ligands is necessary on all complexes for oxidative addition to occur, except on the most reactive aryl iodides. It is noteworthy that the success of cyclopalladated, phosphine-free, nitrogen-based ligands in the Heck arylation has been reported (13); these ligands have thermal and air stability and in certain cases can deliver turnover numbers in excess of one million.

Whatever the chosen combination of palladium complex and ligand, the catalytically active species is assumed to be the 14-electron complex $\text{Pd}(0)\text{L}_2$ (1 in Scheme II) (5, 6). Oxidative addition of the alkyl or aryl halide can then occur, at (a), to afford the *trans*- RPdXL_2 species, 2, followed by loss of one of the ligands to create a vacant site where alkene co-ordination occurs, at (b). The co-ordinated alkene forms an unstable σ -bonded complex, and the desired product is delivered after a β -hydride elimination, at (c). One problem that can arise with couplings of unsymmetrical alkenes is that of regioselectivity. This factor is considered to be under steric control as the R group adds to the less substituted carbon of the double bond of the incoming alkene (3, 14). The regioselectivity of the Heck reaction has been demonstrated

to be highly dependent on the alkene substituents and also on whether mono- or bidentate ligands are chosen (5, 15, 16). The factors contributing to electronic control for α - or β -arylation have been described and are discussed below (15, 17).

The Role of the Counter Ion

The general mechanism of the Heck reaction as shown in Scheme II has been modified independently by Ozawa and Hayashi (18) and by Cabri and Candiani (5) to define the role played by the counter ion, X. Thus, the co-ordination/insertion process (b) in Scheme II can be viewed as a combination of two separate pathways: (i) and (ii), as shown in Scheme III. In pathway (i) of this model, X remains co-ordinated throughout the cycle. This can occur when X = halide and the alkene co-ordinates upon the dissociation of one of the other ligands (L).

Alternatively, if the Pd-X bond is more labile, as in the case where X is triflate, OTf, the ligands remain bound, and alkene insertion occurs at the site vacated by X, which results in a cationic palladium complex (ii)a by pathway (ii). Further studies have indicated that the reactivities of the cationic complex (ii)a and the neutral complex (i)a are dependent upon the electronic nature of the alkene substrate. Electron-rich alkenes react faster with cationic palladium complexes and conversely, the

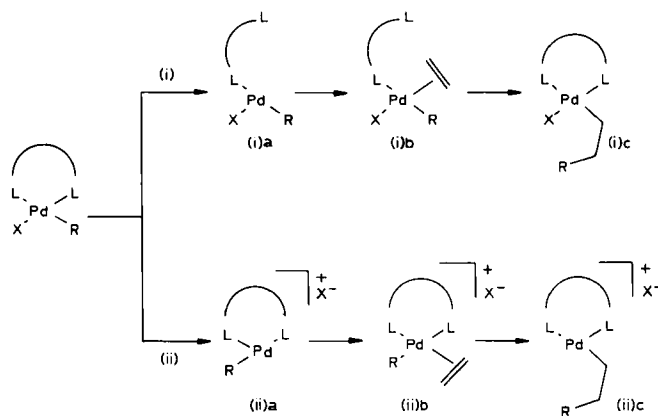

Scheme III

The two possible reaction pathways showing the part played by the counter ion, X. In pathway (i) if X = halide, the X remains co-ordinated to the palladium, and the ligand L dissociates; while in (ii) if the Pd-X bond is more labile, such when if X = OTf, both ligands, L, remain bound, with alkene insertion occurring at the site vacated by X

reaction of electron-deficient substrates is faster when neutral palladium complexes are used (5, 15, 16). Also, the introduction of halide-removing agents, such as AgNO₃ or TlOAc allows replacement of the strong Pd-X bond with a more labile one. The effect of the leaving group and of the alkene substituents on the coupling reaction has been elucidated by Cabri and Candiani by using the expanded co-ordination/insertion cycle, see Scheme III (5).

Åkermark and co-workers have also investigated the effect of counter ions on the regioselectivity of the Heck reaction (16). The reaction of a cationic Pd species with electron-rich alkenes mainly results in α -substitution, whereas β -substitution is the predominant reaction with electron-poor substrates (16).

Reaction Conditions and General Trends

Conventionally, the Heck reaction is performed by the combination of an appropriate alkenyl or aryl halide (Scheme I) with a slight excess of the alkene and a base, usually an amine in the presence of the Pd(OAc)₂/triarylphosphine catalyst system under an inert atmosphere. The most commonly employed base is triethylamine, but

a wide range of both organic and inorganic bases (NaOAc, NaHCO₃, and K₂CO₃), in addition to Proton Sponge* (1,8-bis(dimethylamino)-naphthalene) and Ag(I)/Tl(I) salts, have been found effective (5). Common reaction temperatures are between 60 to 150°C, though this range can vary considerably depending on the reactants: some reactions of aryl iodides can be carried out at room temperature, while aryl chlorides are essentially unreactive at temperatures below 120°C. Most alkenyl and aryl halides, however, do react at room temperature under high pressure or with Jeffery's phase-transfer conditions (*vide infra*). Tertiary phosphines are usually employed to maintain the stability of the catalyst. (It is noted, however, that these phosphines can also react under the standard Heck conditions to form a phosphonium salt (19). In some cases, Pd-catalysed transfer of aryl groups from the triarylphosphine to the substrate is observed (3)).

Substrates/Substituents Used in the Heck Reaction

Aryl, heterocyclic, benzylic, and vinylic iodides and bromides have been used as substrates (3, 4). A wide variety of substituents can be present

in the aryl halide, but with two limitations: (a) halides in possession of β -hydrogens cannot be used as they undergo elimination, and (b) the utilisation of chloro- and fluoroarenes has not been generally successful since these compounds demonstrate considerably lower reactivities than do their iodo and bromo counterparts (3, 5, 7). No examples of Heck reactions which use aryl or alkenyl fluorides as substrates have been documented to date, while traditionally, chlorides (other than benzylic chlorides) require harsh conditions.

The Use of Aryl Chloride as Substrates

The use of aryl chlorides for industrial application would be attractive as they are readily available in bulk quantity and are much less expensive than the equivalent iodo and bromo compounds. Progress has recently been made in this area and it has been established that the Heck coupling of aryl chlorides can proceed, with yields of 70 to 85 per cent in the presence of sterically hindered, electron-rich phosphines, in particular P(*t*-Bu)₃ and P(cyclohexyl)₃. The improved reactivities arise from the easier oxidative addition of the aryl chloride to the more electron-rich palladium centre (20). Other examples of the use of aryl chlorides have been given in a comprehensive review (21).

Selective coupling catalysed by Pd(OAc)₂ occurs at the iodo position when both bromo and iodo substituents are present (22). The bromo group can be subsequently reacted with additional alkene if a triarylphosphine is added to the Pd(OAc)₂ catalyst.

The utilisation of aryl and vinyl triflates as substrates in the Heck reaction is now becoming more frequent (5, 16, 18) and a selection of alternate reactants have also been evaluated. Coupling reactions with aryl diazonium salts can be achieved at room temperature; these include the reaction of endocyclic enecarbamates with aryl diazonium salts in place of ArX (Ar = aryl), and allowed the production of some pyrrolidine alkaloids and a novel C-aryl aza-sugar (23).

The Heck reaction of various aryl bromides with secondary amines has been employed for

the preparation of aryl amines in high yield with sodium *tert*-butyrate as base. The palladium-catalysed P-C coupling reaction between selected aryl iodides and primary and secondary phosphines has been described and yields for this novel route to water-soluble phosphines are as high as 98 per cent (24).

Solvents

A wide variety of solvents has also been investigated for use in the Heck reaction. Among the more commonly used are dipolar aprotic solvents, such as DMF, DMSO, *N*-methylpyrrolidone (NMP) and acetonitrile. Other solvents which can be used are methanol, hexamethylphosphoramide, *N,N*-dimethylacetamide and even water. In particular, the coupling of cyclic alkenes and aryl iodides in high temperature water was investigated, the reactions being performed over 3 hours at 175 to 225°C and at pressures \leq 100 bar (25).

When fluorinated palladium complexes are used as the catalyst, reactions can be performed in supercritical carbon dioxide and with lower catalyst loadings and temperatures (75 to 80°C) than are usually required for the Heck reaction, giving yields of up to 96 per cent (26). One unusual line of study made use of vodka as the solvent and a commercial animal worm medicine as the base (27)!

Heck couplings can also be performed under phase-transfer conditions by the procedure developed by Jeffery, where the addition of quaternary ammonium salts, such as tetraalkylammonium chloride, bromide or hydrogen sulfate caused an enhancement in both the reactivity and the selectivity compared to the standard Heck reaction (28–30). However, in general, the combination of catalyst/base/salt must be fine-tuned to obtain optimum conditions (31).

Products from the Heck Reaction

The preparation of *E*-benzylidenesuccinate diesters *via* the Heck coupling of aryl halides and itaconic diesters has been reported. Subsequent asymmetric hydrogenation of the Heck product produces chiral 2-benzylsuccinic acid derivatives, which are highly desirable

chiral building blocks (19).

The "unnatural" amino acid, 2,6-dimethyl-L-tyrosine, was synthesised via Heck coupling of the aryl component 3,5-dimethyl-4-iodo-phenyl acetate and 2-acetamidoacrylate in acetonitrile under reflux, to afford the coupling product in 85 per cent yield. An asymmetric hydrogenation followed by hydrolysis then gives the desired amino acid in 87 per cent yield (32).

Heterogeneous Catalysis in Heck Coupling Reactions

As palladium has a high susceptibility to poisoning, relatively large amounts of palladium (1–5 mol%) must be employed to achieve acceptable conversions. Thus, the use of heterogeneous catalysis is a very attractive industrial alternative to homogeneous catalysis, due to the ease of recovery (filtration) and recycling of the metal.

Most examples of the Heck reaction in the literature are of homogeneous catalysis and describe the use of organopalladium complexes (usually with phosphine ligands, as previously mentioned). However, in recent years, as indicated by the quantity of reports in the literature, there has been a growing interest in the heterogeneous variant of the Heck reaction. There is still controversy as to the mechanism of this reaction: whether it is still homogeneous, even with a heterogeneous catalyst, and has just a simple dissolution of metal from the catalyst support. Examples of some systems, which have been used with varying degrees of success, are described below.

- The regiochemistry of the Heck reaction catalysed by a supported palladium reagent has previously been shown to depend on the characteristics of the support material: acidic supports mainly resulting in linear product and basic materials predominantly giving branched product. Consequently, a catalyst system was developed where the regioselectivity of the Heck arylation could be modified by the application of an electrical potential to the catalyst (palladium/graphite) (33).
- A palladium/porous glass catalyst has also been used for Heck couplings, with palladium

loadings of between 0.02 and 0.18 per cent (34).

- Palladium catalysts supported on glass beads in ethylene glycol have also been successfully applied to the Heck reaction, with moderate yields (27 to 75 per cent) and very low levels of palladium leaching (35).
- Heterogeneous catalysts comprising polymer-supported palladium and clay-supported Pd-Ph₂P-Si have been employed for the coupling reaction (17, 36). However, drawbacks to the Pd-Ph₂P-Si systems include the large number of steps required in the preparation and the use of costly phosphorus and silicon reagents.
- A palladium-copper-exchanged montmorillonite K10 clay catalyst has been described, which can catalyse the preparation of stilbene from aryl halides and styrenes with yields as high as 93 per cent (37).
- Another polymer-bound palladium catalyst, (polymer)-phenyl-(1,10-phenanthroline)-palladium(0), has been found to couple various substituted iodobenzenes and acrylamide successfully, to produce cinnamamides (38). This polymeric catalyst showed no decrease in activity after 10 recycles. In one example, the polymeric complex yielded the desired product, whereas the equivalent homogeneous system showed no reaction after 24 hours at 130°C.
- Another novel heterogeneous catalyst system, consisting of palladium-grafted molecular sieves, has proved very successful for C-C bond formation (39). For example, *n*-butyl acrylate and 4-bromoacetophenone were coupled to afford the cinnamic acid in 99 per cent yield after 60 minutes (120°C) with a turnover number (TON) of 5000 using 2 mol% of catalyst.
- Other attempts include the use of a palladium species entrapped in various zeolites (40) and supported Pd(0)/MO_x catalysts, where MO_x = MgO, ZnO, CaO, TiO₂, SiO₂ and Al₂O₃ (41).
- A different approach has been taken by Novartis AG, where palladium-catalysed coupling occurred between terminal acetylenes and alkenes with aryl iodides which were linked to a polystyrene resin (42).
- Furthermore, a palladium/carbon (Pd/C) catalyst has been employed for arylation reactions of enol ethers (15, 43).

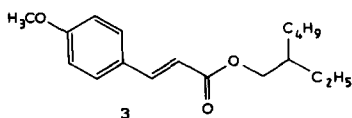

Fig. 1 Octylmethoxycinnamate, a UV-B filter which is produced by a heterogeneous Heck reaction using a Pd/C catalyst

The preparation of commercially relevant compounds via the heterogeneous Heck reaction has been reported previously (44–46). For example, octylmethoxycinnamate, **3**, see Figure 1, which is the UV-B filter used in sun screens, has been prepared in up to 92 per cent yield with a Pd/C catalyst. Homo- and hetero-substituted benzophenones, used as monomers and pharmaceutical intermediates, have also been prepared (46).

Our interest in the Heck reaction was to investigate further the use of Pd/C as a catalyst for the preparation of a variety of products. Results and conditions for its use will be discussed in more detail.

Recent Studies into Palladium/Carbon Catalysed Arylation Heck Coupling

Ongoing studies in our laboratory are focused on the heterogeneous Heck reaction for the formation of substituted cinnamic acids, which are used as substrates for the synthesis of unnatural amino acids by the use of phenylalanine ammonia lyase. There have been periodic references in the literature to the use of Pd/C for this Heck arylation, but reports of its use are still quite limited – in comparison to alternate homogeneous and heterogeneous systems.

Our experiments are typically performed by the combination of the aryl bromide, an alkene and NaHCO₃/NaOH in a solution of NMP/H₂O

under nitrogen. The anti-oxidant, 2,6-di-*t*-butyl-4-methylphenol (BHT), is added to the reaction mixture to inhibit or hinder the polymerisation of the alkene, which occurs at temperatures above 70°C; the temperature range required for successful reaction is ≥ 100°C (44, 46). The catalyst employed is 5 per cent Pd/C, used in a 1 per cent ratio to aryl bromide. The reaction is monitored by gas chromatography until the complete consumption of the aryl bromide has been detected. After removal of the catalyst by filtration, the isolation procedure for the product involves water dilution, acidification and finally filtration to afford the cinnamic acid product in 64 to 90 per cent yield.

2-Acetamidoacrylic acid has also been evaluated as the alkene substrate in the heterogeneous Heck reaction under similar conditions. However, in all of the experiments attempted to date, no evidence of the desired product has been detected, although this reaction has been successful under homogeneous conditions, see Scheme IV (32, 47).

A very strict nitrogen atmosphere is essential for the successful completion of the Pd/C catalysed arylation of acrylic acid. If air is not completely excluded, the desired product will not be formed.

The aryl bromides employed in our studies to date have been 1- and 2-bromonaphthalene, 2-, 3- and 4-bromobenzonitrile, 4-chlorobromobenzene and 2,4-difluorobromobenzene with the alkene substrate being either acrylic acid or 2-acetamidoacrylic acid, see the Table. The main set of reactions are heterogeneous in nature using Pd/C, but in some cases the homogeneous variant has been run for comparison purposes. The homogeneous catalyst systems which have been employed so far are palladium acetate with two equivalents of triphenylphosphine or, alternatively, dichlorobis(triphenylphosphine)-

Scheme IV

2-Acetamidoacrylic acid undergoing a homogeneous Heck arylation reaction with added base

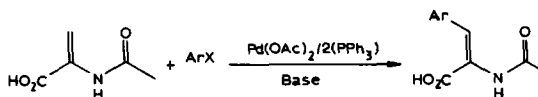

Palladium Catalysed Arylation Heck Coupling Reactions ^a			
Aryl bromide	Alkene	Catalyst	Yield, per cent
1-Bromonaphthalene	Acrylic acid	Pd/C	70
	2-Acetamidoacrylic acid	Pd(OAc) ₂ /PPh ₃ Pd/C	27 NR ^b
2-Bromonaphthalene	Acrylic acid	Pd/C	79
		Pd(OAc) ₂ /PPh ₃	81
2-Bromobenzonitrile	Acrylic acid	Pd/C	90
3-Bromobenzonitrile	Acrylic acid	Pd/C	83
		Pd(OAc) ₂ /PPh ₃	68 (49) ^c
		Pd(Cl) ₂ (PPh ₃) ₂	84
4-Bromobenzonitrile	Acrylic acid	Pd/C	NR ^d
		Pd(OAc) ₂ /PPh ₃	64
		Pd(Cl) ₂ (PPh ₃) ₂	79 87
4-Chlorobromobenzene	Acrylic acid	Pd/C	68
2,4-Difluorobromobenzene	Acrylic acid	Pd/C	76

a All reactions carried out in NMP according to described procedure unless otherwise stated

b NR = No reaction

c Acetonitrile solvent, triethylamine as base

d Acetonitrile solvent, tributylamine as base

palladium(II). Our initial results have shown that similar yields can be obtained with either homogeneous or heterogeneous catalysts in the arylation of acrylic acid to cinnamic acids. The homogeneous system also successfully arylated 2-acetamidoacrylic acid in contrast to the heterogeneous system, which was completely unreactive and investigations into the reason for this are presently being undertaken.

Conclusion

Since its discovery in 1968, the Heck reaction has progressively become an indispensable tool for the synthesis of carbon-carbon bonds. However, the suitability of the Heck reaction for

industrial purposes must be developed. The applicability of the reaction to asymmetric synthesis adds a further dimension to the study, and several inter- and intramolecular variants of asymmetric Heck reactions have been described. With the homogeneous reaction, various levels of success have been reported in preparing a selection of natural products, depending on the chiral ligand used in the palladium complex.

Ongoing studies of the reaction by ourselves and others are aimed at the elaboration of this versatile reaction in regard to general reaction conditions and substrates, and of course the palladium catalyst, where the mechanism of the heterogeneous reaction is still unknown.

References

- 1 R. F. Heck, *J. Am. Chem. Soc.*, 1968, **90**, (20), 5518
- 2 R. F. Heck, *Acc. Chem. Res.*, 1979, **12**, 146
- 3 R. F. Heck, *Org. React.*, 1982, **27**, 345
- 4 R. F. Heck, "Palladium Reagents in Organic Syntheses", Academic Press, London, 1985
- 5 W. Cabri and I. Candiani, *Acc. Chem. Res.*, 1995, **28**, 2
- 6 A. de Meijere and F. E. Meyer, *Angew. Chem., Int. Ed. Engl.*, 1994, **33**, 2379
- 7 G. T. Crisp, *Chem. Soc. Rev.*, 1998, **27**, 427
- 8 SciFinder search on Heck couplings and the Heck reaction, (May 26th 1999)
- 9 W. Cabri, I. Candiani, A. Bedeschi and R. Santi, *J. Org. Chem.*, 1993, **58**, 7421

- 10 W. Cabri, I. Candiani, A. Bedeschi and R. Santi, *Synlett*, 1992, 871
- 11 W. A. Herrmann, M. Elison, J. Fischer, C. Kocher and G. R. J. Artus, *Angew. Chem., Int. Ed. Engl.*, 1995, **34**, 2371
- 12 D. S. McGuinness, K. J. Cavell, B. W. Skelton and A. H. White, *Organometallics*, 1999, **18**, 1596
- 13 M. Ohff, A. Ohff and D. Milstein, *Chem. Commun.*, 1999, 357
- 14 H. A. Dieck and R. F. Heck, *J. Am. Chem. Soc.*, 1974, **96**, 1133
- 15 C.-M. Andersson and A. Hallberg, *J. Org. Chem.*, 1987, **52**, 3529
- 16 M. Ludwig, S. Stromberg, M. Svensson and B. Åkermark, *Organometallics*, 1999, **18**, 970
- 17 C.-M. Andersson, K. Korabelas and A. Hallberg, *J. Org. Chem.*, 1985, **50**, 3891
- 18 F. Ozawa, A. Kubo and T. Hayashi, *J. Am. Chem. Soc.*, 1991, **113**, 1417
- 19 M. A. Schmidt, J. J. Talley, M. G. Scaros and P. K. Yonan, Chemical Industries, "Catalysis of Organic Reactions", Decker, New York, 1995, **62**, 105
- 20 A. F. Littke and G. C. Fu, *J. Org. Chem.*, 1999, **64**, (1), 10
- 21 V. V. Grushin and H. Alper, *Chem. Rev.*, 1994, **94**, 1047
- 22 J. E. Plevyak, J. E. Dickerson and R. F. Heck, *J. Org. Chem.*, 1979, **44**, (23), 4078
- 23 D. F. Oliveira, E. A. Severino and C. R. D. Correia, *Tetrahedron Lett.*, 1999, **40**, (11), 2083
- 24 O. Herd, A. Hebler, M. Hingst, M. Tepper and O. Stelzer, *J. Organomet. Chem.*, 1996, **522**, 69
- 25 L. U. Gron, Book of Abstracts, 215th ACS National Meeting, Dallas, TX, March 29–April 2, 1998, INOR-269
- 26 N. Shezad, R. S. Oakes, A. A. Clifford and C. M. Rayner, *Tetrahedron Lett.*, 1999, **40**, 2221
- 27 A. S. Ross and T. E. Goodwin, Book of Abstracts, 211th ACS National Meeting, New Orleans, LA, March 24–28th, 1996, CHED-122
- 28 T. Jeffery, *Tetrahedron Lett.*, 1985, **26**, 2667
- 29 T. Jeffery, *Synthesis*, 1987, 70
- 30 T. Jeffery, *J. Chem. Soc., Chem. Commun.*, 1984, 1287
- 31 T. Jeffery, *Tetrahedron*, 1996, **52**, (30), 10113
- 32 J. H. Dygos, E. E. Yonan, M. G. Scaros, O. J. Goodmonson, D. P. Getman, R. A. Periana and G. R. Beck, *Synthesis*, 1992, 741
- 33 S. A. Roberto and R. L. Augustine, Chemical Industries, "Catalysis of Organic Reactions", Decker, New York, 1996, **68**, 465
- 34 L. Jintong, A. W.-H. Mau and C. R. Strauss, *Chem. Commun.*, 1997, 1275
- 35 L. Tonks, M. S. Anson, K. Hellgardt, A. R. Mirza, D. F. Thompson and J. M. J. Williams, *Tetrahedron Lett.*, 1997, **33**, (24), 4319
- 36 B. M. Choudhary, R. M. Sarma and K. K. Rao, *Tetrahedron*, 1992, **48**, 719
- 37 R. K. Ramchandani, B. S. Uphade, M. P. Vinod, R. D. Wakharkar, V. R. Choudhary and A. Sudalai, *Chem. Commun.*, 1997, 2071
- 38 Z. Zhuangyu, P. Yi, H. Honwen and K. Tsi-yu, *Synthesis*, 1991, 539
- 39 C. P. Mehnert, D. W. Weaver and J. Y. Ying, *J. Am. Chem. Soc.*, 1998, **120**, 12289
- 40 L. Djakovitch and K. Kohler, Book of Abstracts, RSC (Dalton) 9th Int. Symp. on Relations between Homogeneous and Heterogeneous Catalysis, University of Southampton, 20–24 July, 1998
- 41 M. Wagner and K. Kohler, Book of Abstracts, RSC (Dalton) 9th Int. Symp. on Relations between Homogeneous and Heterogeneous Catalysis, University of Southampton, 20–24 July, 1998
- 42 S. Berteina, S. Wendeborn, W. K.-D. Brill and A. De Mesmaeker, *Synlett*, 1998, (6), 676
- 43 C.-M. Andersson and A. Hallberg, *J. Org. Chem.*, 1988, **53**, 235
- 44 A. Eisenstadt, R. Hasharon, Y. Keren and K. Motzkin, *U.S. Patent* 5,187,303; 1993
- 45 P. Gygax, *U.S. Patent* 5,457,226; 1995
- 46 A. Eisenstadt, Chemical Industries, "Catalysis of Organic Reactions", Decker, New York, 1998, **75**, 415
- 47 M. Cutolo, V. Fiandanese, F. Naso and O. Sciacovelli, *Tetrahedron Lett.*, 1983, **24**, (42), 4603

Improved Adhesion of Platinum to Polymers

Poly(vinylidene fluoride) (PVDF), a polymer with piezoelectric properties, is extensively used in IR sensors, ultrasonic transducers, biomaterials and microactuators. Electrodes attached to the PVDF are conventionally made of copper and aluminium as they adhere well to its surface. More suitable inert metals, such as platinum and gold, with higher work functions, which would prevent current leakage, have not been used because of their poor adhesion.

Now, researchers in Korea have devised a method to enhance the adhesion of PVDF to platinum (S. Han, S. C. Choi, W.-K. Choi, H.-J. Jung, S.-K. Koh, K. H. Yoon and H. K. Lee, *J. Mater. Sci. Lett.*, 1999, **18**, (7), 509–513).

The surface roughness of PVDF sheets was increased when irradiated with Ar⁺ ions in flowing oxygen at ~10⁻⁴ Torr, and 1 keV potential. A platinum overlayer, ~100 nm thick, deposited by ion beam sputtering on the irradiated PVDF had greatly improved adhesion. The contact angle between irradiated PVDF and distilled water dropped from 70° to 31°.

Oxygen atoms may be partly replacing fluoride atoms on the carbon chain of the PVDF; hydrophilic functional groups related to oxygen are generated, aided by the ion assisted radiation. The hydrophilic groups may provide adsorption sites for the platinum metal layer, which results in enhanced adhesion.